





Referenz-Nr. Order No.		m	h		s	e1	e2	d	SW		L	b	e3	c	
			min	max											
1150-118 DT	18	M16	48	113	18-96	173	90	M20	12		140	55	48	19.5	6625
1150-120 DT	20	M16	48	113	18-96	173	90	M20	12		140	55	48	19.5	6690
1150-122 DT	22	M16	48	113	18-96	173	90	M20	12		140	55	48	19.5	6750
1150-124 DT	24	M16	48	113	18-96	173	90	M20	12		140	55	48	19.5	6840
1150-128 DT	28	M16	48	113	18-96	173	90	M20	12		140	55	48	19.5	6960
															
1160-222 DT	22	M20	79	139	17-92	235	114	M24	12	24	178	74	59	24	13330
1160-224 DT	24	M20	79	139	17-92	235	114	M24	12	24	178	74	59	24	13465
1160-228 DT	28	M24	79	139	17-92	235	114	M24	12	24	178	74	59	24	13580
1160-236 DT	36	M24	79	139	17-92	235	114	M24	12	24	178	74	59	24	13890

### 1150

- Verwendung mit Imbusschraube M16 DIN 508 und T-Nutmutter
- Spannhöhe 48-113 mm
- Spannkraft 2500 kg.

### 1150

- M16 imbus bolt is used with DIN 508 "T" clamp.
- Height clamping gap of the piece is 48-113mm
- Clamping Force is 2500kgf

### 1160

- Verwendung mit Imbusschraube M20-M24 DIN 508 und T-Nutmutter
- Spannhöhe 79-139 mm
- Spannkraft 5500 kg.

### 1160

- M20-M24 imbus bolt is used with DIN 508 "T" clamp.
- Height clamping gap of the piece is 79-139mm
- Clamping Force is 5500kgf

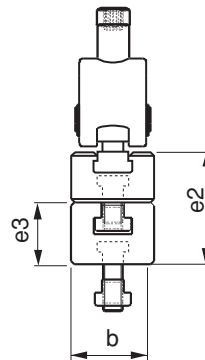
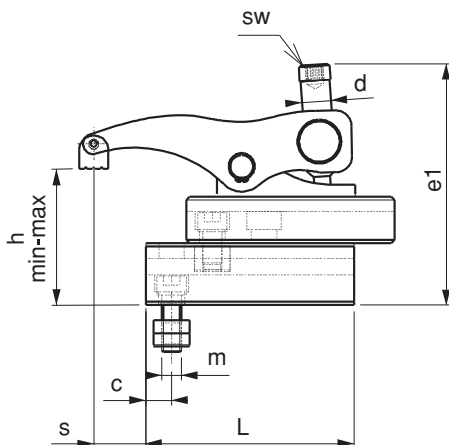

### ANWENDUNG;

- 1- Zwischenstück an Werkstück befestigen
- 2- Höhen-Anpassung durch weitere Zwischenstücke
- 3- Grundkörper auf Zwischenstück schieben, Imbusschraube auf T-Nut positionieren
- 4- Werkstück mit Imbusschraube befestigen

### APPLICATION

- 1- Bottom support is brought to suitable form with the work piece and then it is fixed.
- 2- Desired distance is reached by increasing K.K.S.P supports
- 3- K.K.S.P is applied in "T" slot with imbus bolt against "T" clamp
- 4- Work piece is fixed with the imbus bolt of the clamp

