

Makina Titreşim Tamponları ES SERİSİ

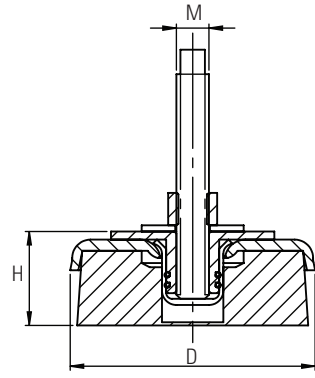

KOD	D (mm)	Civata	Civata Boyu	H (mm)	Ayar Mesafesi	Taşıma kg / adet
ES 1 EKO	80	M12x1.25	120	38	12	290
ES1	80	M12x1.25	120	45	12	500
ES1/A	80	M16x1.5	120	45	12	500
ES1/B	80	M10x1.5	100	45	12	500
ES2	120	M16x1.5	120	45	15	1.000
ES2/A	120	M12x1.25	120	45	15	1.000
ES2/B	120	M16x2	120	45	15	1.000
ES3	160	M16x1.5	120	54	15	2.000
ES4	160	M20x1.5	170	55	15	4.000
ES5	200	M20x2.5	170	55	25	5.000
ES6	200	M24x3	170	55	25	6.000
ES7	240	M20x2.5	170	65	25	7.000
ES7/A	240	M24x3	170	65	25	8.000
ES7/B	240	M30x3.5	170	65	25	9.000

Makina Titreşim Tamponları ESM SERİSİ

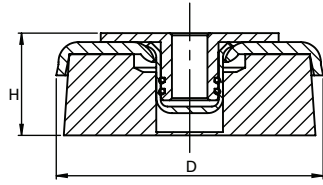

KOD	D (mm)	H (mm)	Taşıma kg / adet
ESM 80	80	40	500
ESM 120	120	40	1.000
ESM 160	160	40	2.000
ESM 200	200	50	4.000

Makina Tamponları SL SERİSİ

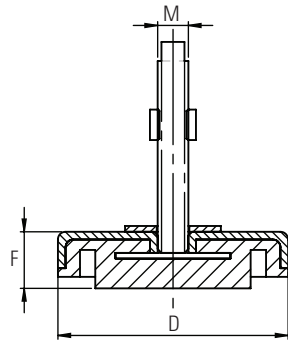

KOD	D (mm)	Civata	Civata Boyu	H (mm)	Ayar Mesafesi	Taşıma kg / adet
SL 080 12	80	M12	100	32	8	300
SL 080 16	80	M16	120	32	8	400
SL 120 12	120	M12	100	35	12	700
SL 120 16	120	M16	120	35	12	800
SL 160 16	160	M16	120	40	12	1200
SL 160 20	160	M20	150	40	12	1500

Döküm Gövde Makina Tamponları ED SERİSİ

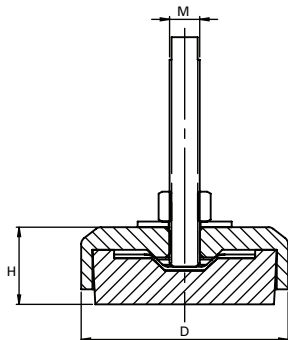

KOD	D (mm)	Civata	Civata Boyu	H (mm)	Ayar Mesafesi	Taşıma kg / adet
ED1	70	M12x1.25	120	40	10	400
ED2	110	M16x1.5	120	42	15	600
ED3	150	M16x1.5	120	45	15	1.000
ED4	160	M20x1.5	170	45	18	1.500